

Special Ed



PHYSICS
9 UNITS 28 WEEKS



ALSO INCLUDES GOOGLE SLIDES



For students who:

- are emerging or non-readers
- take alternate assessments
- are in special education
- short-attention span
- lack pre-requisite skills
- benefit from the use of pictures for support
- middle/high school

Why you need this curriculum:

- If you teach multiple grade levels, you have all you need in one place.
- Having the same layout for each unit reduces students' anxiety and allows them to focus on the content.
- Aligned with extended learning standards.
- Saves you money
- Saves you time.

This bundle includes 9 different units that are typically part of a high school physics curriculum. It includes:

1. Electricity and Circuits (3 weeks)
2. Light Energy (3 weeks)
3. Electromagnetic Spectrum (2 weeks)
4. Motion Graphs (3 weeks)
5. Potential and Kinetic Energy (3 weeks)
6. Simple Machines (5 weeks)
7. Sound Energy (3 weeks)
8. Thermal Energy (3 weeks)
9. Types of Forces (3 weeks)

All units have
printable
AND digital
versions

All the units contain similar activities so students become familiar with the format and can concentrate more on the content. Although there is some variation, each unit has:

- Detailed lesson plans
- A book PLUS a pre-recorded PowerPoint show and movie version
- Vocabulary cards
- Circle maps
- Sorting activities
- Labeling activities
- Experiments
- Close worksheets (fill in the blank)
- Assessments (3 versions)

All units have
printable
AND digital
versions

Table of Contents

Pages	Activity
4-5	Vocabulary board
6-10	Vocabulary cards
11-22	Vocabulary cut and paste
23-30	Flash cards
31-49	Circle maps
50-61	Sorting Activities
62-64	Matching the machine to the job
65-81	Simple Machine Experiments
82-88	Sudoku
89-90	Word Search
91-100	Cloze worksheets
101-112	Assessment
113-114	Terms of Use

Also included in this resource as separate files:

- Lesson plans
- Links and directions to digital activities
- PowerPoint **(this is the book in the lesson plan)**
- Voice recorded PowerPoint
- Activities in black and white

Each unit has a table of contents. There is a separate file with directions and links to the digital activities.

Day 2

Activity	Notes	Materials
Read or listen to a recording of the book (15 minutes)	<ul style="list-style-type: none">• Read through the story, asking lots of questions• Continue to make connections between book and vocabulary board	<ul style="list-style-type: none">• Book• Vocabulary board
Vocabulary cards I Spy Game (10 minutes)	<ul style="list-style-type: none">• I play this game, or variations of it the first few days<ul style="list-style-type: none">◦ Determine how many cards your students can handle in front of them. This can vary, some students may be able to have all the cards, so may only be able to handle a field of 3-5• Since this is the first time playing this game, I make it easy. Hold up a card, and have students find the matching one and hold it up• Discuss relevant points on the card<ul style="list-style-type: none">◦ You can also play this game in this manner having them find the symbol on their vocabulary board	<ul style="list-style-type: none">• Vocabulary cards (student set and teacher set)• Vocabulary board
Circle map review (5 minutes)	<ul style="list-style-type: none">• Review the circle map completed yesterday	<ul style="list-style-type: none">• Circle map completed yesterday
Circle Map (10 minutes)	<ul style="list-style-type: none">• Do the circle map on opaque objects• Choose the best version (errorless or not) depending on the learning level of your students• Students cut out symbols and place in circle map• Make connections to the book as necessary	<ul style="list-style-type: none">• Circle map• Scissors• Glue
Sharing (10 minutes)	<ul style="list-style-type: none">• Each student shares their finished circle map with the group using the communication method of their choice	<ul style="list-style-type: none">• Completed activity• Communication devices

Lesson plan

Every unit has a detailed lesson plan with:

- suggestions
- overview
- daily step-by-step guide

Book

A battery has 2 terminals. A positive terminal called a **cathode**, and a negative terminal called an **anode**. You will see these are marked by a + and a – sign on a battery.

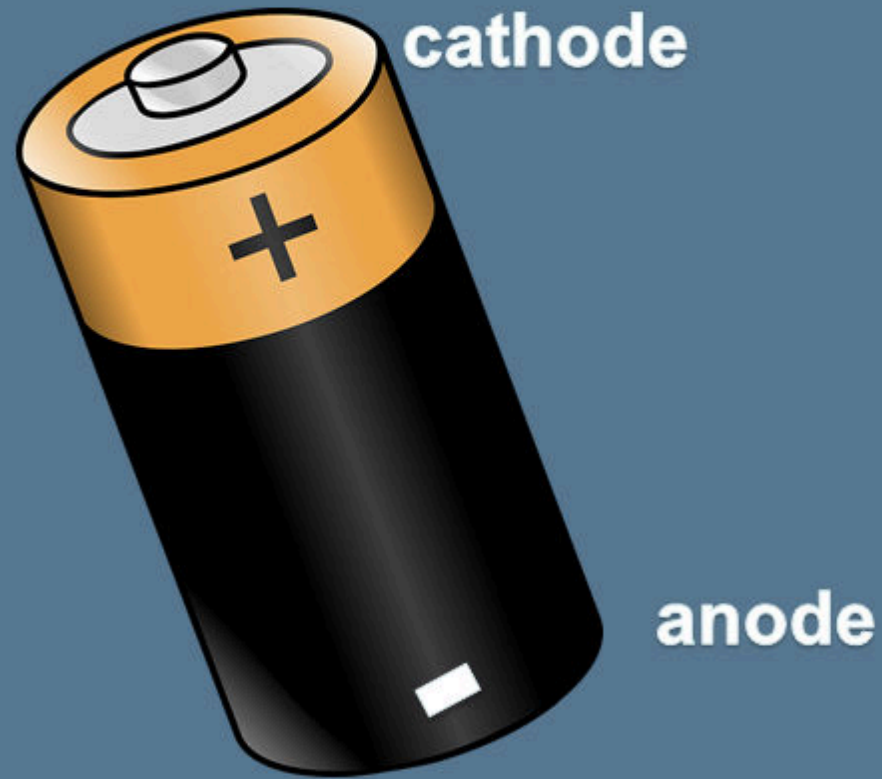

Every unit has a book with simple text and engaging photos. It comes in:

- PowerPoint
- recorded PPT show
- mp4 (movie) file

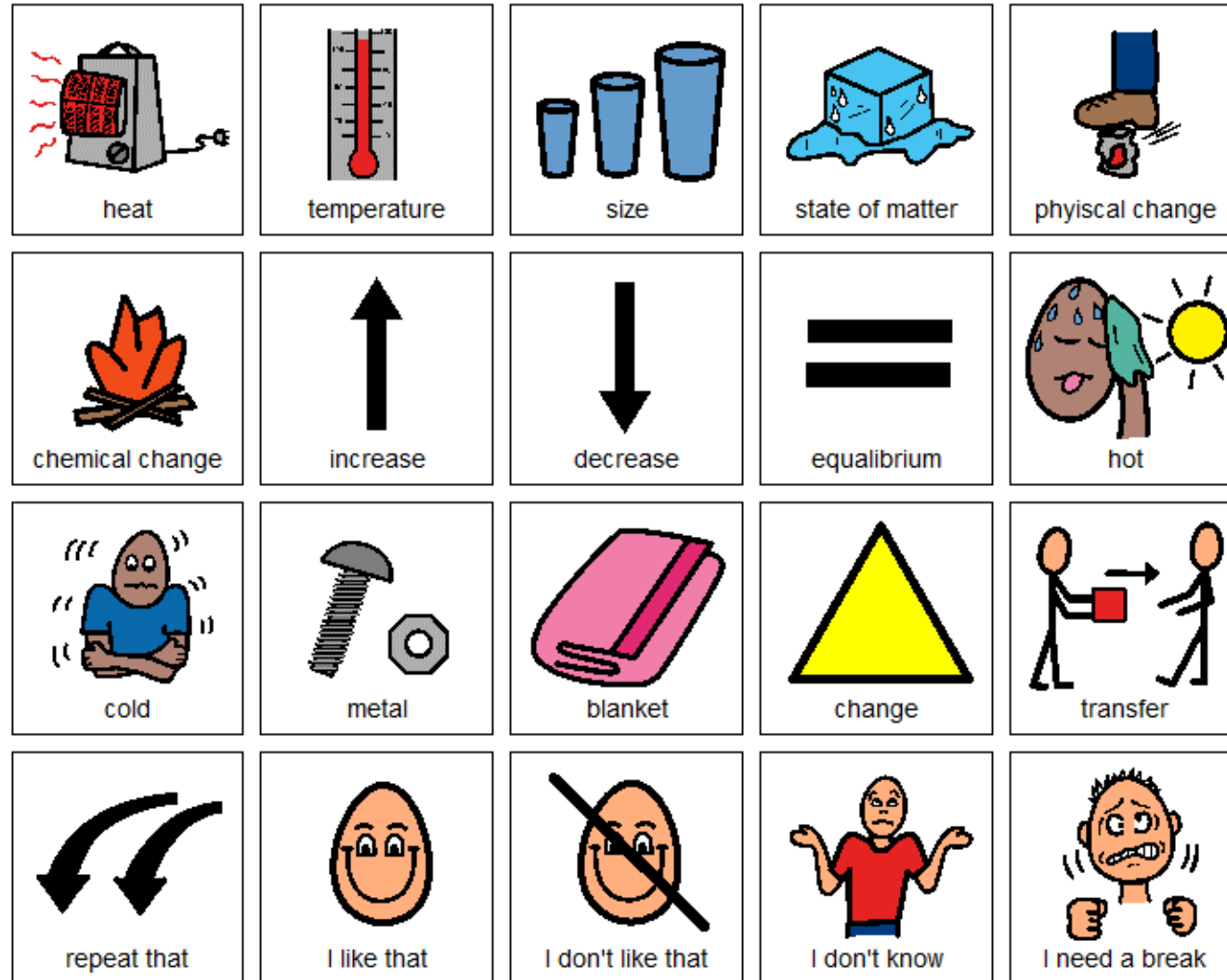

Each unit has a vocabulary board to use while working through the unit. Suggestions for use are included.

Christa Joy, Special Needs for Special Kids
 The Picture Communication Symbols ©1981–2019 by Tobii Dynavox. All Rights Reserved
 Worldwide. Used with permission. Boardmaker® is a trademark of Tobii Dynavox

sound

Form of energy that travels through a medium.



vibrate

Molecules moving very fast.



pitch

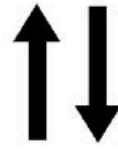

audible



longitudinal wave

A wave that moves through something, pushing the molecules in the same direction it is moving.



frequency

How many vibrations occur in one second.



ultrasounds

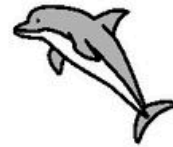

amplitude



intensity

How loud a sound is.



decibels

How the loudness of a sound is measured.

dB

sound

Form of energy that travels through a medium.

vibrate

Molecules moving very fast.

echo

Sound wave that is repeated because it is reflected back off a hard, smooth surface.

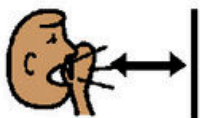

echolocation

Bats send out ultrasounds that are reflected back and show the location of objects.



longitudinal wave

A wave that moves through something, pushing the molecules in the same direction it is moving.

frequency

How many vibrations occur in one second.

Vocabulary

Every unit has vocabulary cards. There are suggestions for daily group activities to review these.

circle maps

Place the pictures in the circle map on previous page about motion graphs.

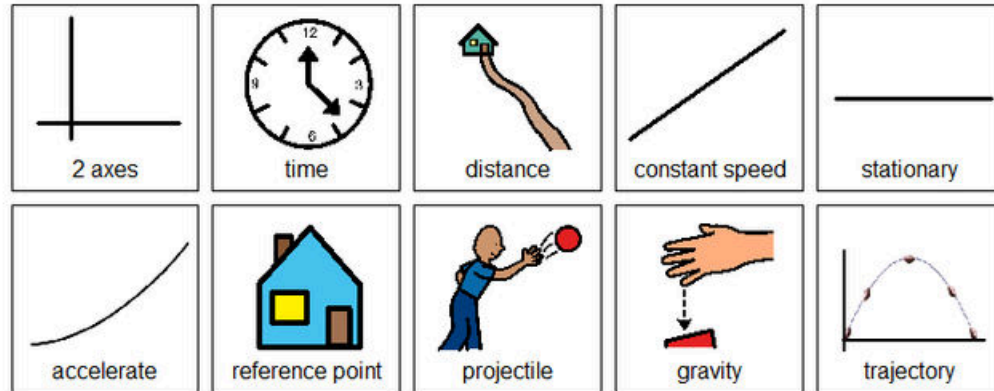



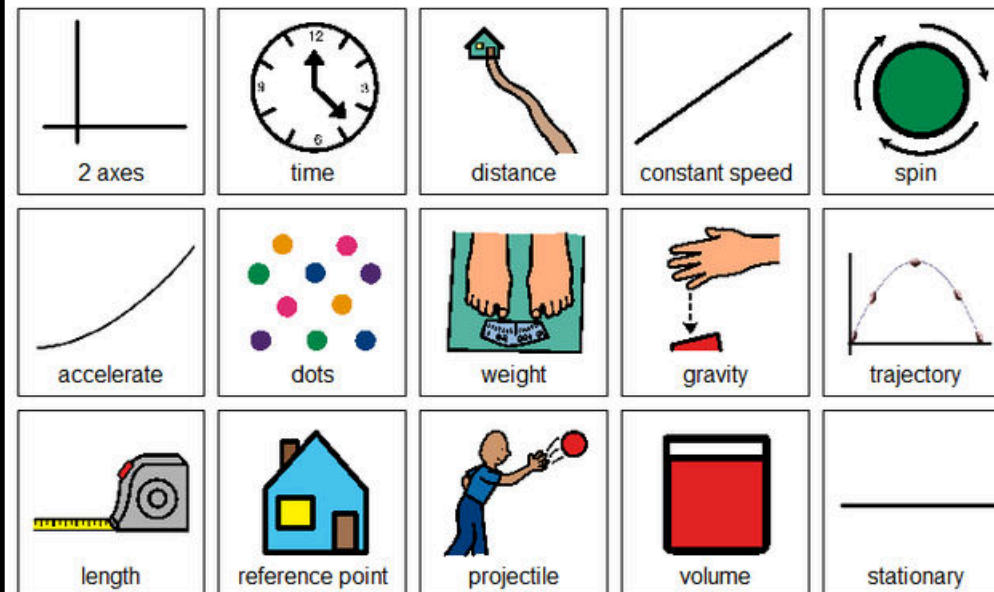





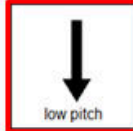

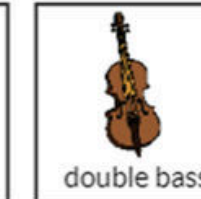

Place the pictures in the circle map on previous page **ONLY IF** you think it relates to motion graphs.











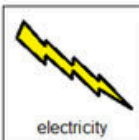

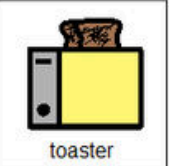

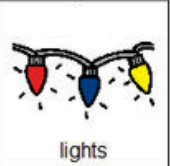



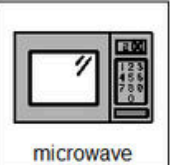



Each unit comes with 1 or more circle maps to visually review the main facts from the book. These come with an errorless option and an option with wrong answers mixed in.

sorting

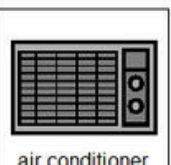
 high pitch	 low pitch		
 ukulele	 cello	 triangle	 double bass
 piccolo	 bass guitar	 flute	 gong
 tuba	 violin	 trumpet	 trombone

Christa Joy, Special Needs for Special Kids
The Picture Communication Symbols © 1981-2020 by Tobii Dynavox. All Rights Reserved
Worldwide. Used with permission. Boardmaker® is a trademark of Tobii Dynavox

 electricity	 no electricity			
 toaster	 toilet	 lights	 kettle	 lamp
 jack-o'-lantern	 hot air balloon	 microwave	 bike	 skateboard
 TV	 sneakers	 oven	 surfboard	 hair dryer
 trampoline	 air conditioner	 computer	 umbrella	 vacuum cleaner

The unit on the periodic table has sorting activities. There are suggestions for how to differentiate these quickly included.

Label the parts and type of a circuit.

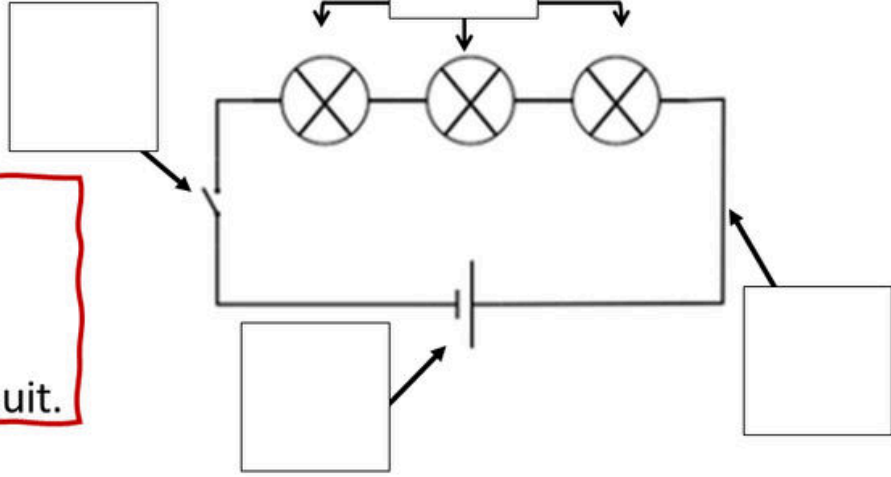

This is a :
 circuit.

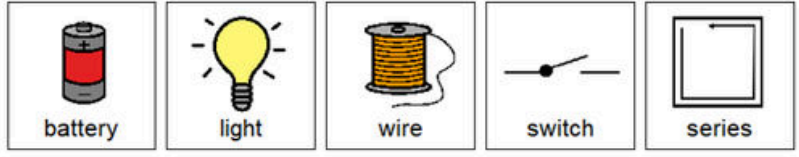

Christa Joy, Special Needs for Special Kids
The Picture Communication Symbols ©1981-2020 by Tobii Dynavox. All Rights Reserved Worldwide. Used with permission. Boardmaker® is a trademark of Tobii Dynavox

There are labeling and activities in both units. Suggestions for differentiation are included.

Label the parts of a battery.

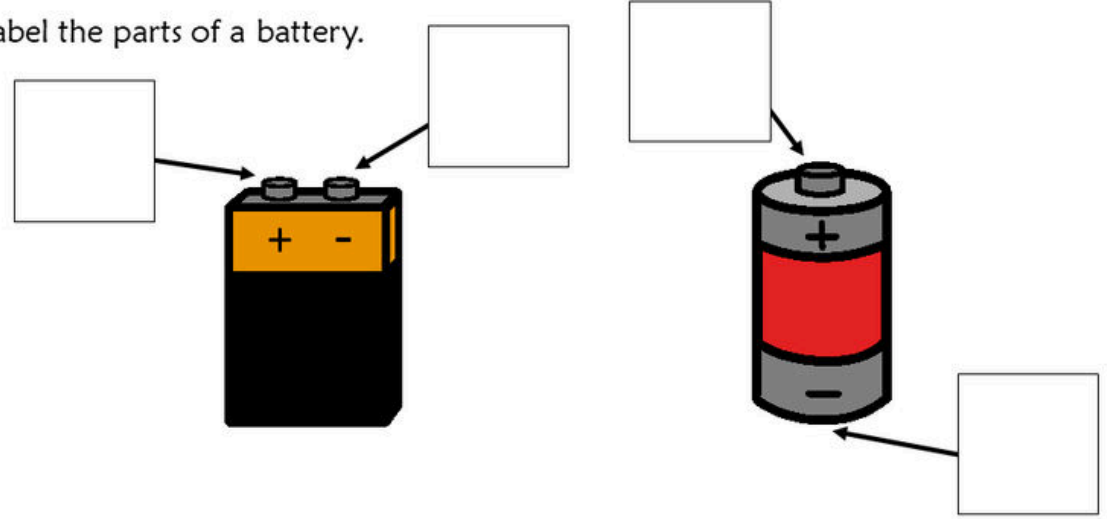

Christa Joy, Special Needs for Special Kids
The Picture Communication Symbols ©1981-2020 by Tobii Dynavox. All Rights Reserved Worldwide. Used with permission. Boardmaker® is a trademark of Tobii Dynavox

labeling

Gravity (Pull) Experiment #2

Incline Ramp

People on my team: _____

Materials needed:

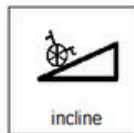

Gravity (Pull) Experiment #2

Incline Ramp

My hypothesis

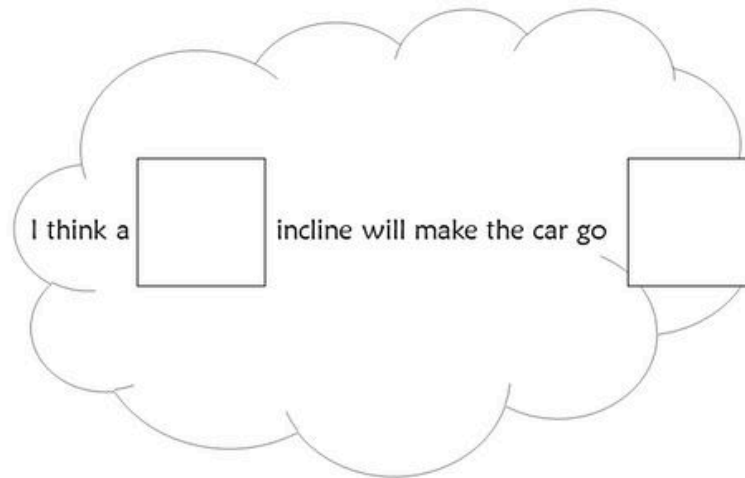

experiments

Gravity (Pull) Experiment #2

Incline Ramp

What I learned

The the ramp, the car traveled.

The the ramp, the car traveled.

The force acting on the car is .

This is a force.

The experiments walk students through the scientific method with lots of visual supports.

Wheel and Axle



1. The axle is attached to the of the wheel.
2. As the axle turns, it causes the wheel to in a balanced circle.
3. Gears are special wheels that have .
4. Most forms of use a wheel and axle.
5. is an example of something that uses a wheel and axle.

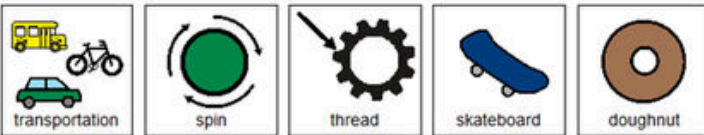

Review sheets

Effects of Heat

1. Heat can an object.
2. When you apply heat to an object, it the temperature.
3. Some objects heat up faster than others. Those that heat up faster and easier are good .
4. is an example of a good conductor.
5. When two objects touch each other, they transfer heat until they both have temperature.



Each unit includes fill-in-the-blank worksheets to review concepts covered in the book and unit. Answer keys included.

1. A force is something that causes an object to:

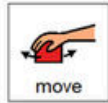

2. One of Newton's laws states that an object in motion, will stay in:



3. All forces are measured in :

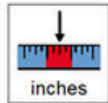

4. A pushing force causes an object to move:

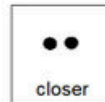
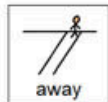

5. A pulling force causes an object to move:



Print onto cardstock or mount on index cards. Cut pictures apart and show student answer choices for each question.

Q 3

J

joules

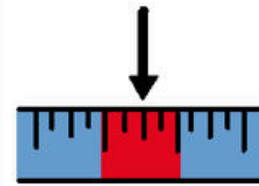

inches

N

newtons

Q 4



no where

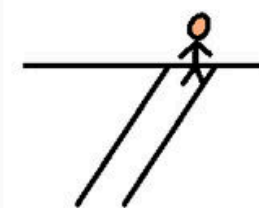

away



closer

- A force is something that causes an object to:
 - Sit down
 - Move
 - Melt
- One of Newton's laws states that an object in motion, will stay in:
 - Motion
 - At rest
 - Swimming
- All forces are measured in :
 - Joules
 - Inches
 - Newtons
- A pushing force causes an object to move:
 - Sit down
 - Away
 - Closer
- A pulling force causes an object to move:
 - Away
 - Over there
 - Closer

Finally, each unit has an assessment that is available in 3 versions. These are given 1:1 and read aloud to the student.

Assessment

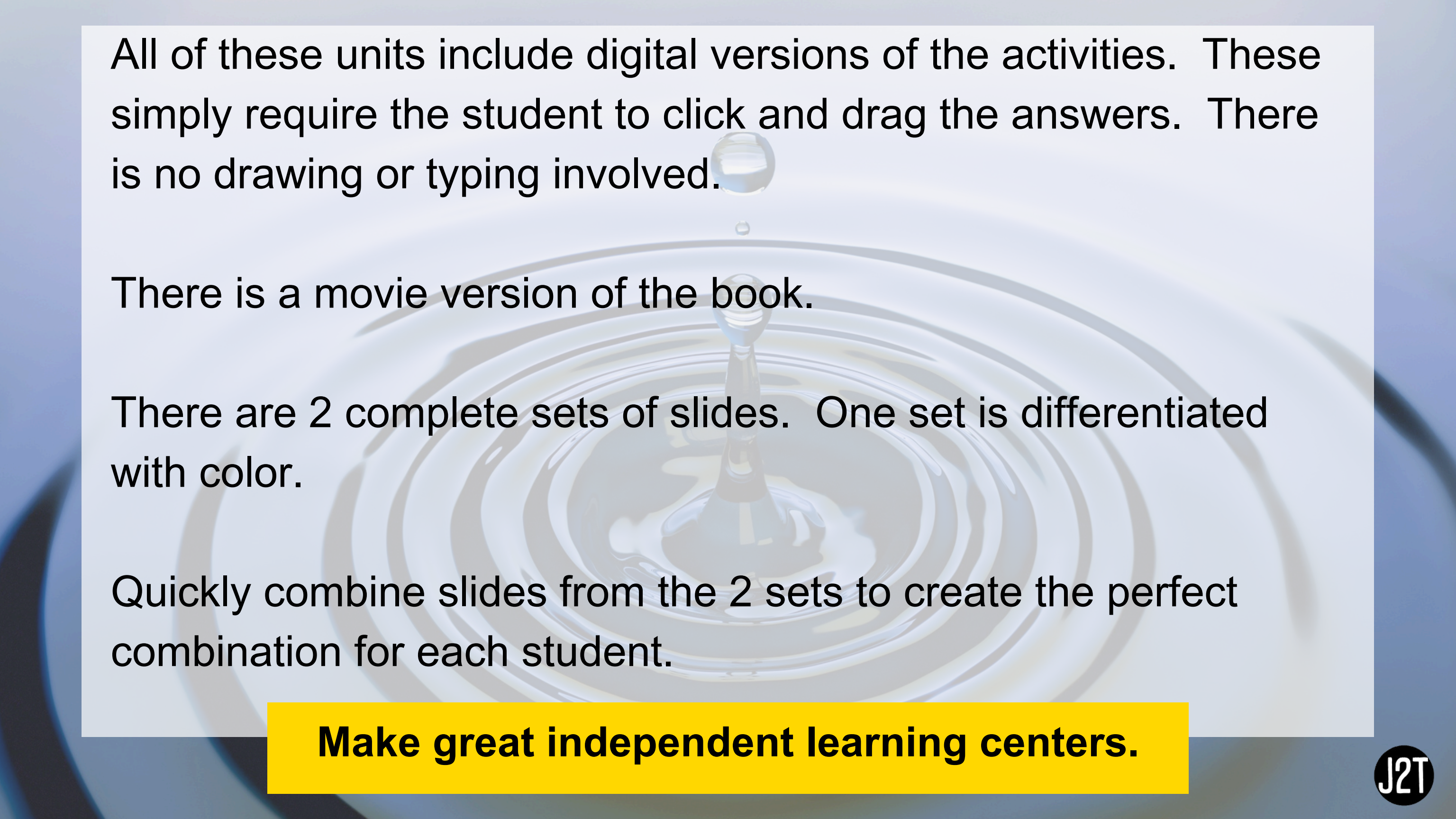

All of these units include digital versions of the activities. These simply require the student to click and drag the answers. There is no drawing or typing involved.

There is a movie version of the book.

There are 2 complete sets of slides. One set is differentiated with color.

Quickly combine slides from the 2 sets to create the perfect combination for each student.

Make great independent learning centers.

Watch the
movie on
Electricity

If you need more energy or electricity going to your object, you can either increase the voltage (get a bigger battery) or decrease the resistance (use better wire).

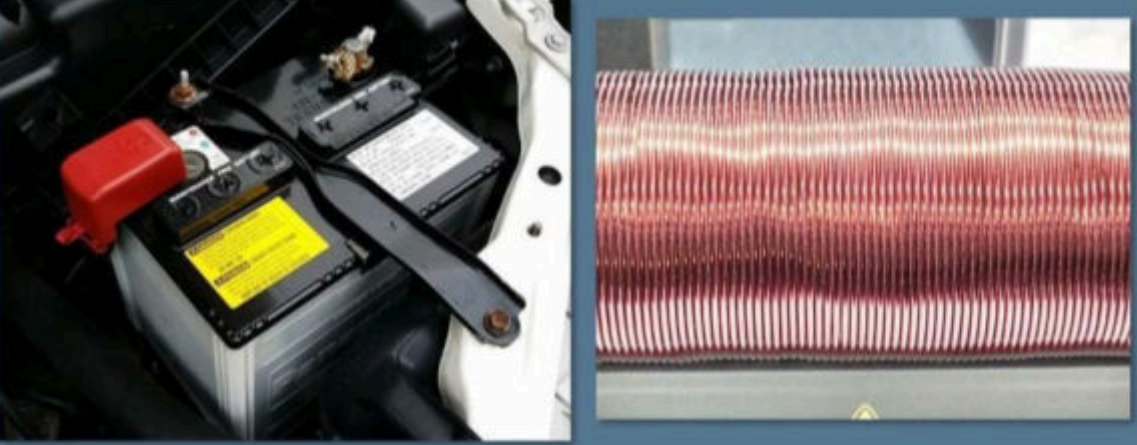

The image contains two photographs. The left photograph shows a car battery with a red positive terminal cover and a black negative terminal cover, with a metal tool resting on top. The right photograph shows a close-up of a coil of copper wire, likely used in an electromagnet or transformer.





Christa Joy, Special Needs for Special Kids

The movie
version of the
book from the
unit.

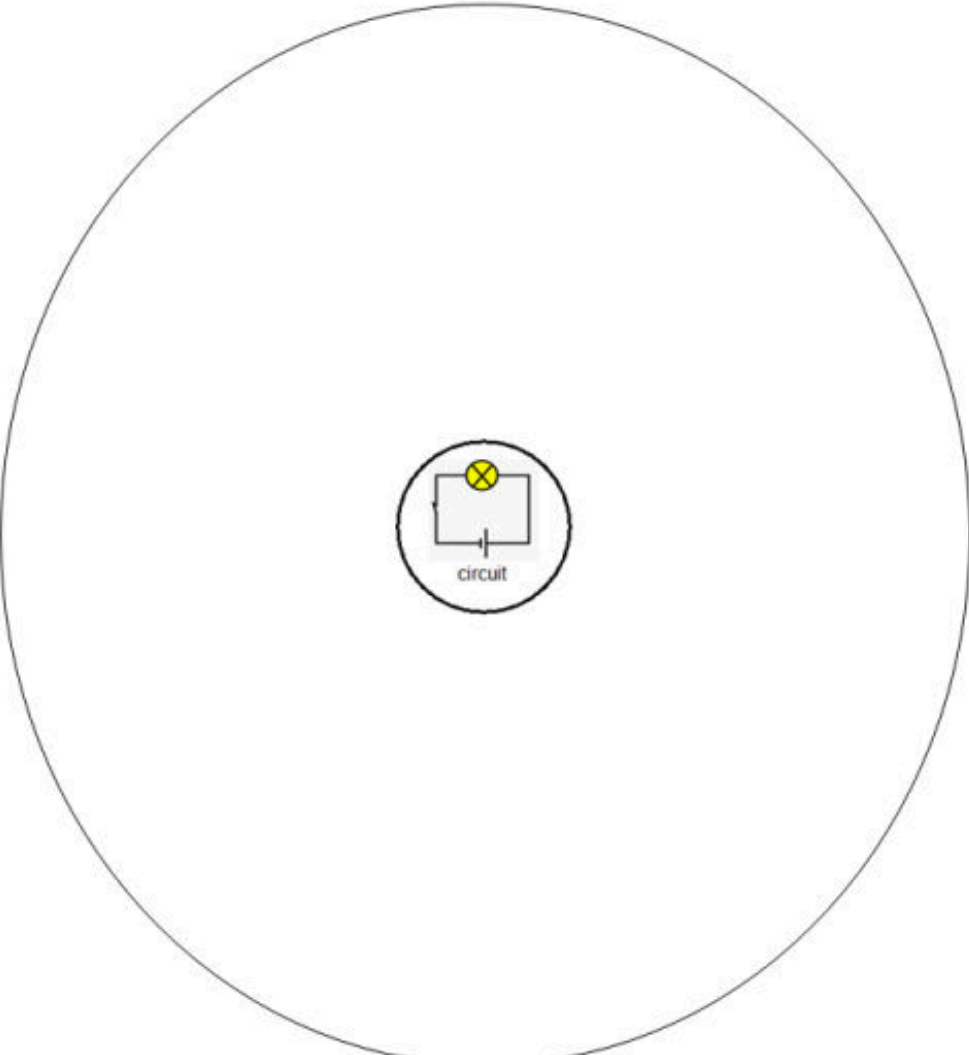
Use for more review.

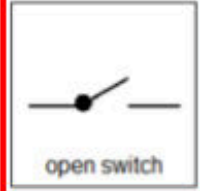
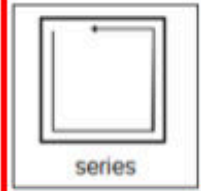
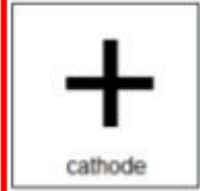
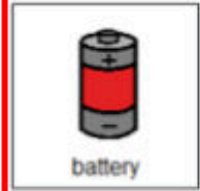
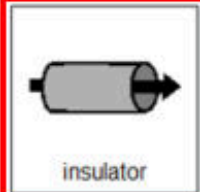
Place the picture in the circle map about circuits.

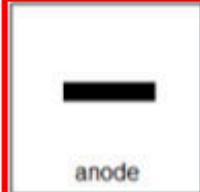
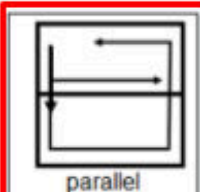

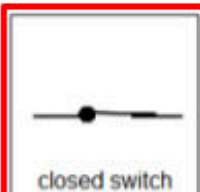
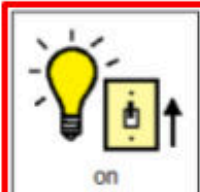
 open switch	 series	 cathode	 battery
 insulator	 resistance	 volts	 anode
 parallel	 conductor	 closed switch	 on

Christa Joy, Special Needs for Special Kids
The Picture Communication Symbols ©1981-2019 by Tobii Dynavox. All Rights Reserved
Worldwide. Used with permission. Boardmaker® is a trademark of Tobii Dynavox

The digital activities are click and drag.

Perfect for any learning level.

Each unit comes with a set of slides that are differentiated with color.

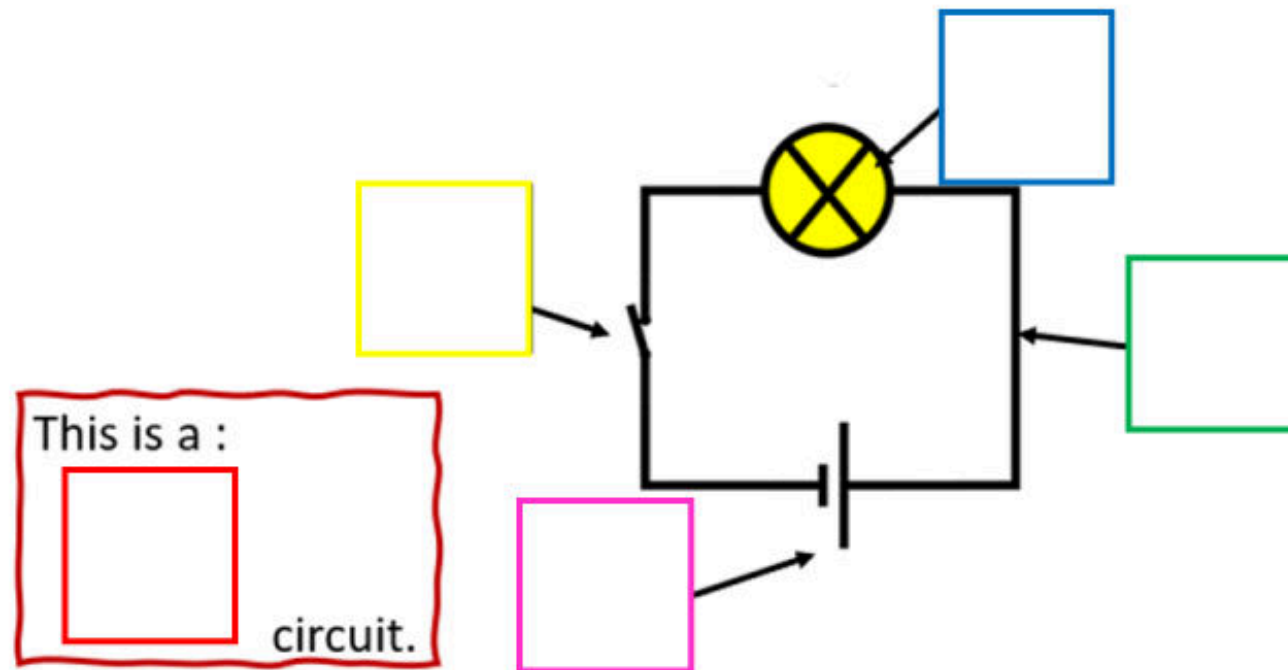

Label the parts of a circuit.

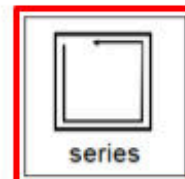
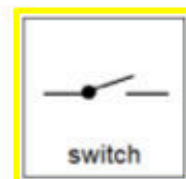
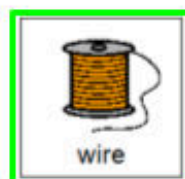

Christa Joy, Special Needs for Special Kids
The Picture Communication Symbols ©1981-2019 by Tobii Dynavox. All Rights Reserved
Worldwide. Used with permission. Boardmaker® is a trademark of Tobii Dynavox

Still have questions?

Reach out at specialneedsforspecialkids@gmail.com

I will answer your question personally and promptly.

