

# IMMUNE SYSTEM

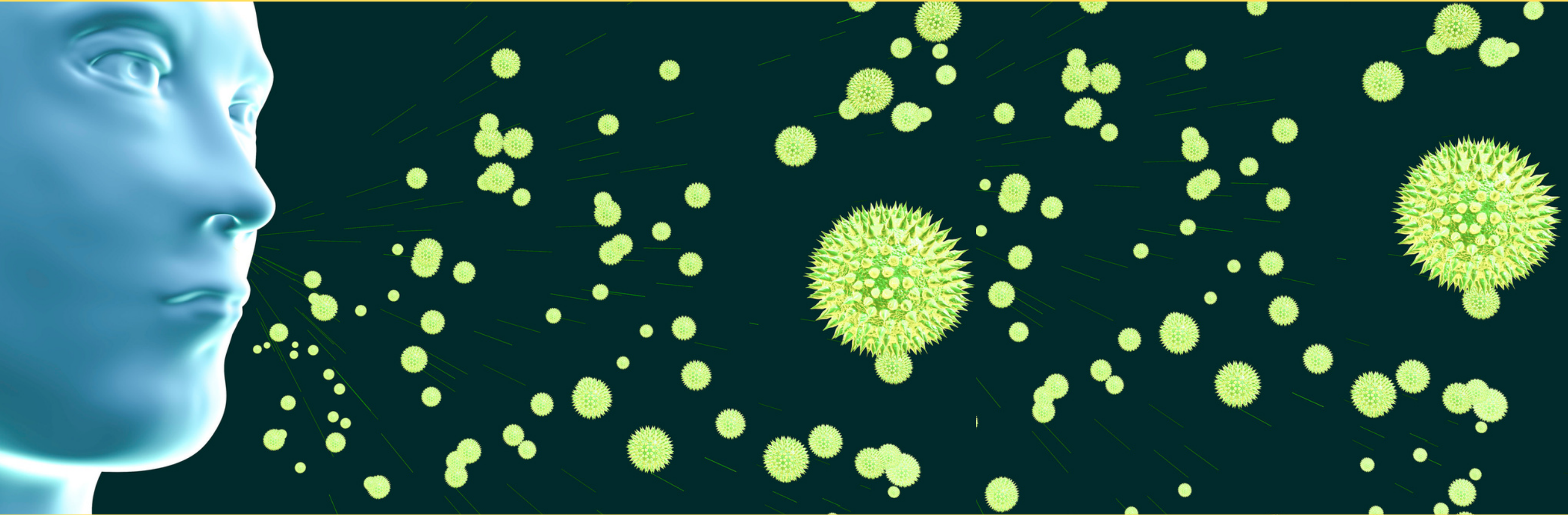

**INCLUDES GOOGLE SLIDES**



## For students who:

- *are emerging or non-readers*
- *take alternate assessments*
- *are in special education*
- *short-attention span*
- *lack pre-requisite skills*
- *benefit from the use of pictures for support*
- *middle/high school*

# Immune System Unit

By  
Christa Joy  
Special Needs for Special Kids

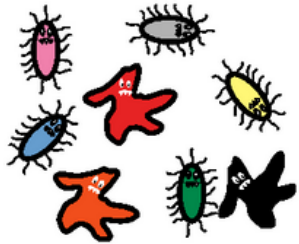

Christa Joy, Special Needs for Special Kids  
The Picture Communication Symbols ©1981-2018 by Tobii Dynavox. All Rights Reserved  
Worldwide. Used with permission. Boardmaker® is a trademark of Tobii Dynavox

## Table of Contents

Pages	Activity
4-5	Vocabulary board
6-10	Vocabulary cards
11-22	Vocabulary cut and paste
23-26	Circle maps
27-30	Matching activities
31-40	Sequencing activity
41-42	Vocabulary Word Search
43-49	Vocabulary Sudoku
50-55	Cloze worksheets
56-66	Assessment
67-68	Terms of Use

### Also included in this resource as separate files:

- Lesson plans
- Links and directions to digital activities
- PowerPoint (this is the book in the lesson plans)
- Voice recorded PowerPoint
- Activities in black and white

This unit contains **9 days** of material. But, don't worry!! I have included a lesson plan to help you make the most of everything packed in this unit.

This unit comes in 2 separate files, one in color and one in black and white.

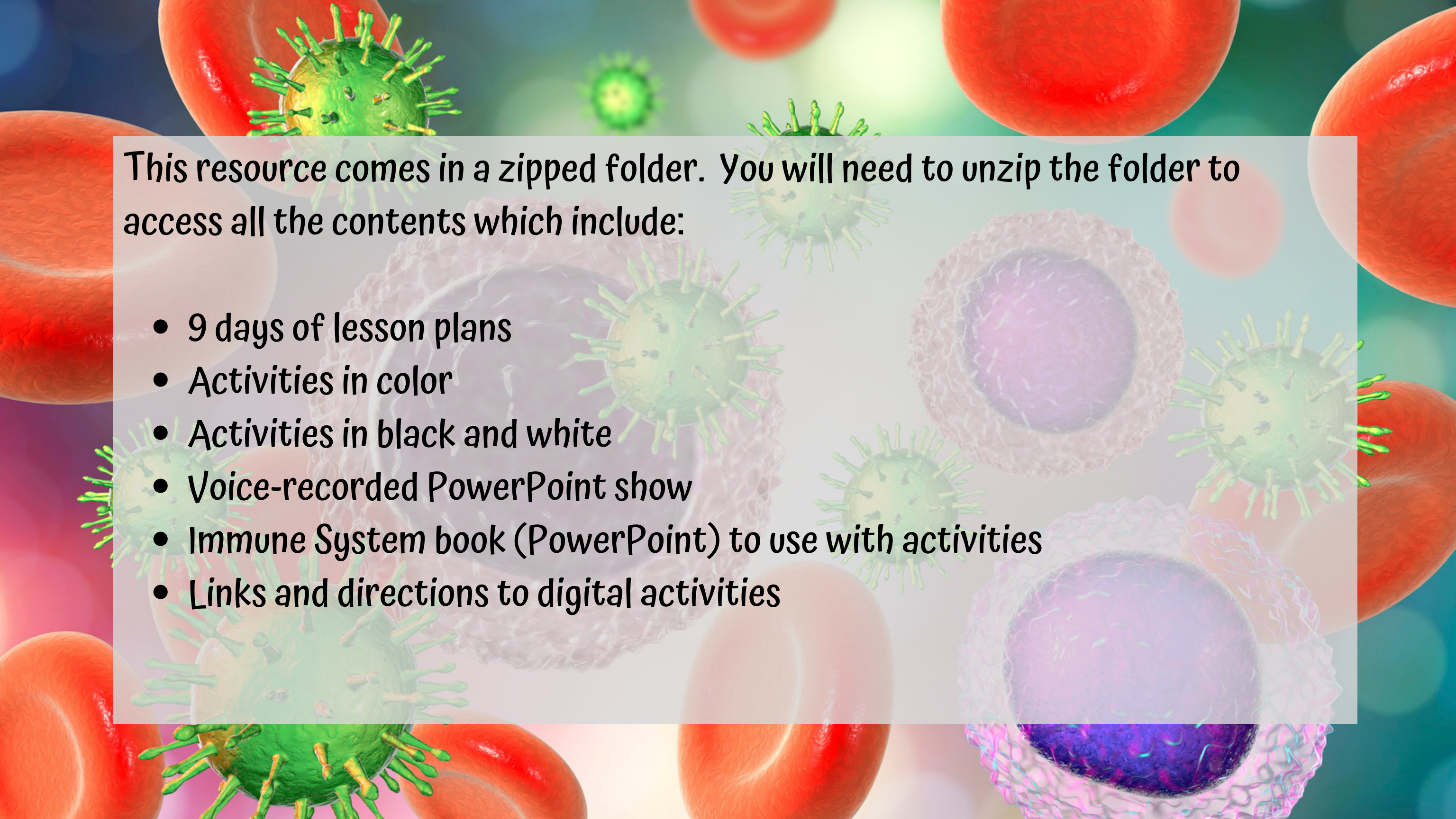
The background features a vibrant, colorful illustration of various biological cells and viruses. In the foreground, there are several large, red, biconcave disc-shaped cells, likely red blood cells. Interspersed among them are several green, spherical viruses with prominent, thin, hair-like spikes protruding from their surfaces. Some of these viruses are shown in a more detailed, close-up view, while others are smaller and more distant. The overall scene is set against a soft, multi-colored background of blues, greens, and pinks, creating a dynamic and scientific atmosphere.

**This resource comes in a zipped folder. You will need to unzip the folder to access all the contents which include:**

- **9 days of lesson plans**
- **Activities in color**
- **Activities in black and white**
- **Voice-recorded PowerPoint show**
- **Immune System book (PowerPoint) to use with activities**
- **Links and directions to digital activities**

## Day 8

Activity	Notes	Materials
Read or listen to a recording of the book (10 minutes)	<ul style="list-style-type: none"><li>• Read through the story, asking lots of questions</li><li>• Continue to make connections between book and vocabulary board</li></ul>	<ul style="list-style-type: none"><li>• Book</li><li>• Vocabulary board</li></ul>
Vocabulary cards Scavenger Hunt (10 minutes)	<ul style="list-style-type: none"><li>• Place one set of the vocabulary cards around the room before lesson</li><li>• Students walk around and find them, bring them back and matching them to their own set of cards</li></ul>	<ul style="list-style-type: none"><li>• Vocabulary cards (extra sets)</li><li>•</li></ul>
Close worksheet review (5 minutes)	<ul style="list-style-type: none"><li>• Review the completed close worksheet from yesterday</li></ul>	<ul style="list-style-type: none"><li>• Completed worksheet</li><li>• Vocabulary board</li></ul>
Close worksheet (10 minutes)	<ul style="list-style-type: none"><li>• Do the remaining close worksheet on disorders of the immune system.</li><li>• Use color coding as needed</li><li>• Students should be able to refer to book or vocabulary cards as needed to find answers</li></ul>	<ul style="list-style-type: none"><li>• Close worksheets</li><li>• Scissors</li><li>• Glue</li><li>• Book</li><li>• Vocabulary cards</li></ul>
Sharing (10 minutes)	<ul style="list-style-type: none"><li>• Each student shares their finished close worksheet</li></ul>	<ul style="list-style-type: none"><li>• Completed activity</li><li>• Communication devices</li></ul>

There is a detailed lesson plan with:

- suggestions
- overview
- daily step-by-step guide

The lymphatic system has 2 main jobs. One is to carry these special cells called **lymphocytes** to the blood stream. From there, they will travel all over the body looking for areas of infection.

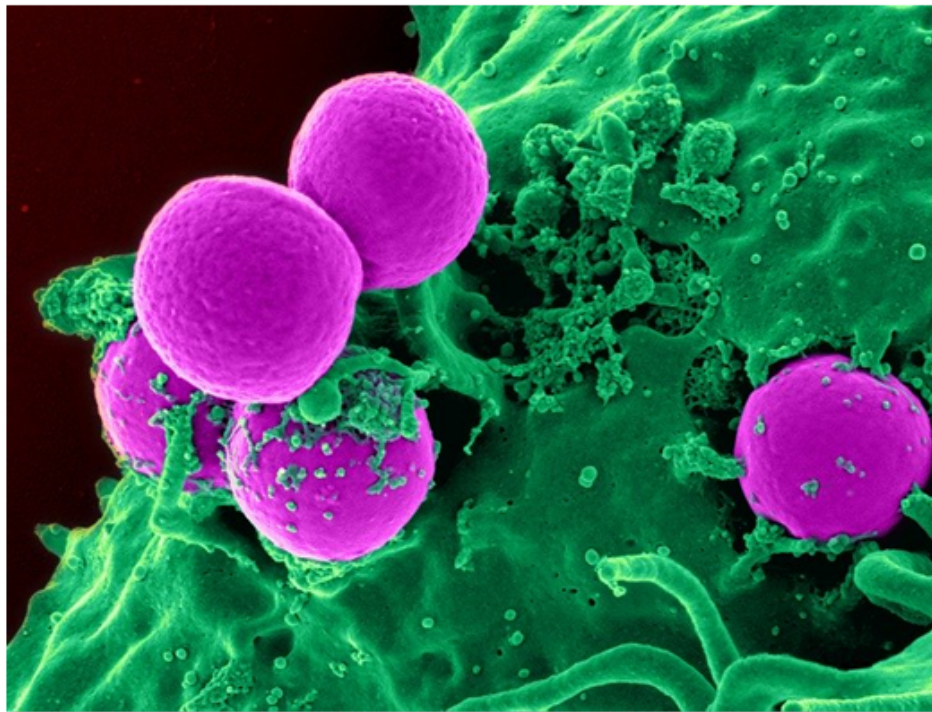

*This unit contains a 40 page book with simple text on the Immune System.*

*It comes in a PowerPoint version as well as a voice-recorded PowerPoint (so you don't have to print it out.) There is also a movie version you can use in google slides.*

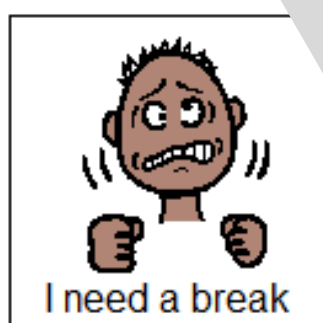
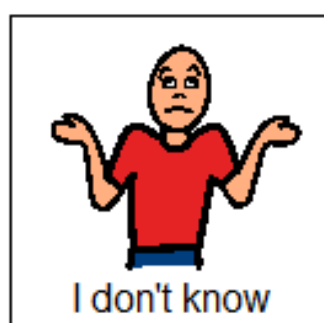
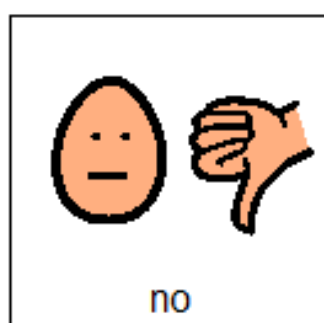
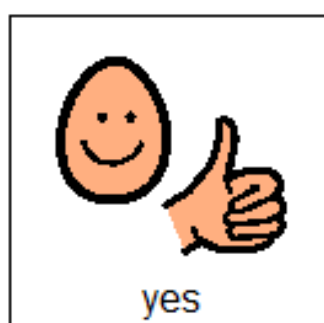
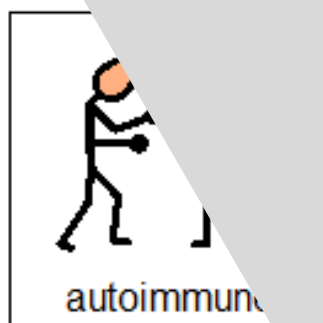
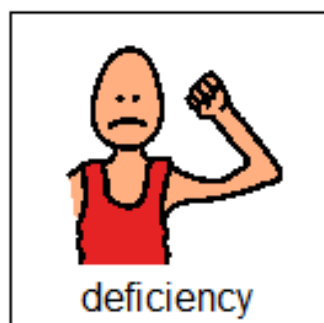
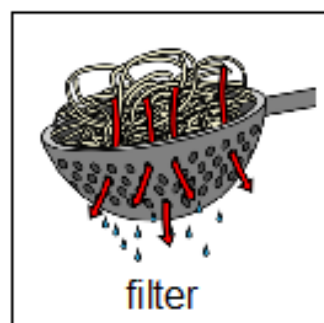
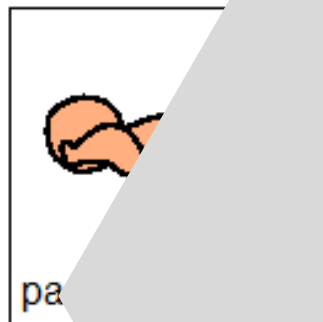
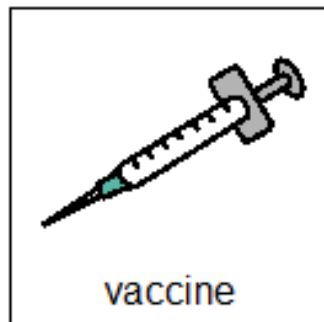
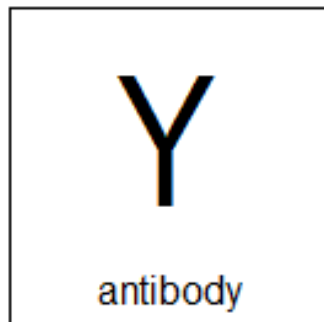
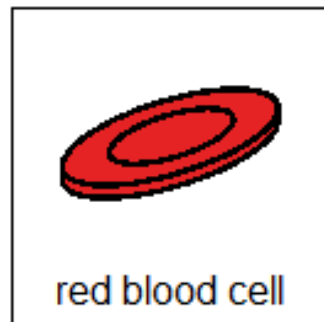
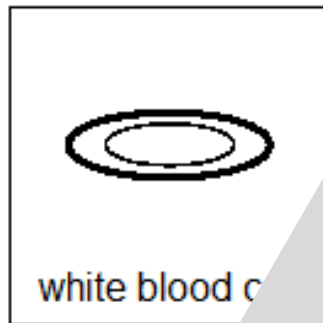
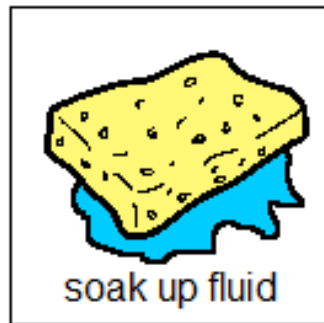
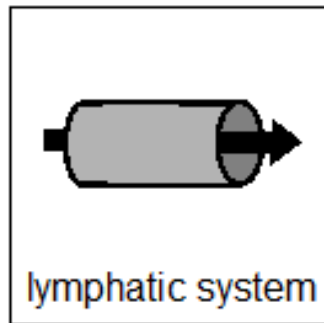
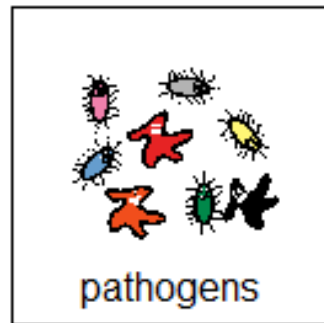

*This unit comes with a vocabulary board.*

*Vocabulary boards are great for ALL students to assist with participation and engagement in group discussions.*

*Tips on how to use in the unit!!*

### immunity

Protection from things that could hurt you.



### pathogen

Something that could make you sick like viruses, bacteria, or parasites.



### thymus

Gland in the chest that creates immune cells ONLY until you are a teenager.



### T-cells

Found in the thymus and help fight off infected and damaged cells.



### lymphatic system

System of vessels that moves fluid and immune cells to the blood stream.



### spleen

Organ in the abdomen that filters out damaged cells and makes immune cells.

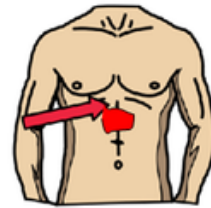

### lymph nodes

Glands in your neck and body that swell and trap the infected cells and pathogens.



In the cell

This unit comes with 16 vocabulary cards.

Every day students will do a group activity using these cards to get more familiar with words that are likely new to them.

### immunodeficiency



### autoimmune



### lymphocytes



### lymph

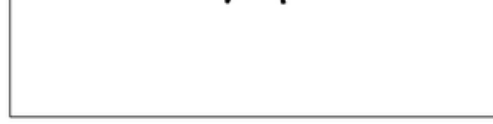

			<b>Y</b>
			<b>T</b>



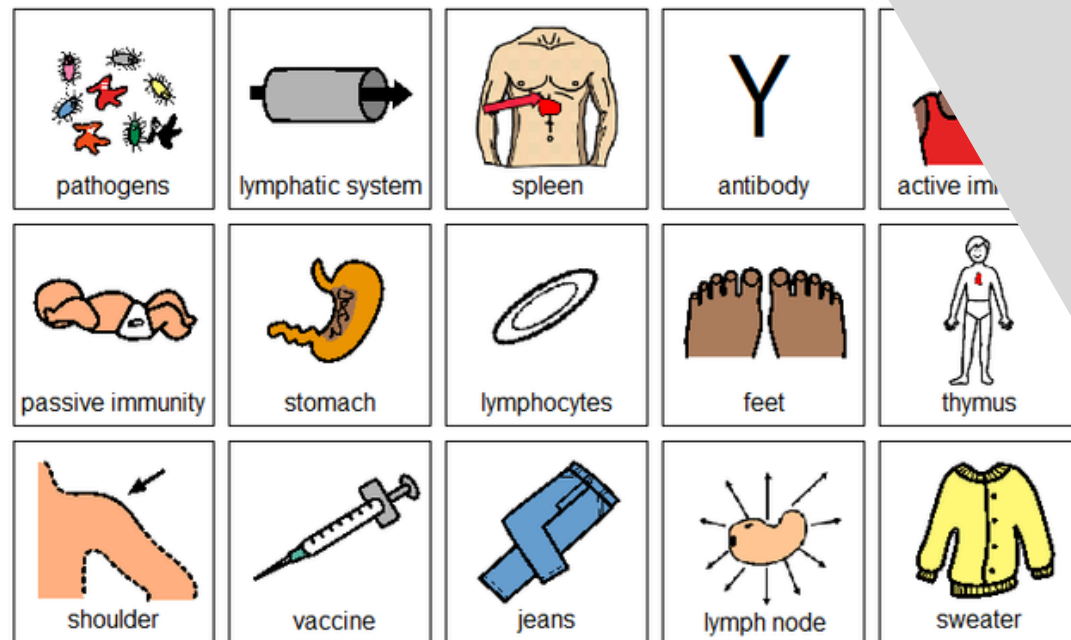
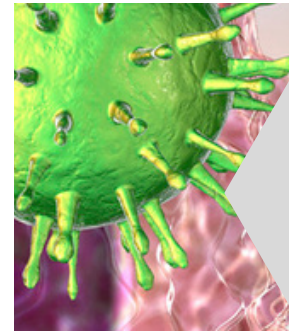
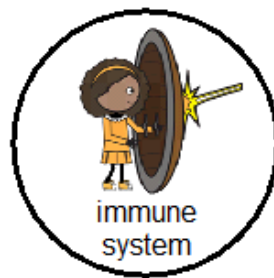
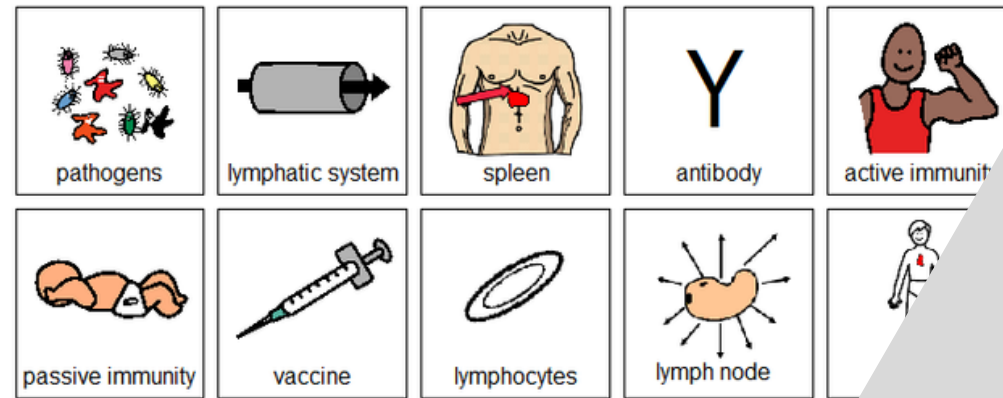

















There is a circle map in this unit.

This circle map is a great way for students to see a concept at a glance. There are 2 versions:

- One is errorless
- One has wrong answers mixed in students will have to set aside

Find the picture that goes with each description below.

 <p>inside bones</p>	 <p>filters old cells</p>
 <p>shrinks as you get older</p>	 <p>fights pathogens</p>
 <p>immunity you build up</p>	 <p>immunity from Mom</p>
 <p>get this from a doctor</p>	 <p>first line of defense</p>

 <p>vaccine</p>	 <p>bone marrow</p>	 <p>active immunity</p>	 <p>spleen</p>
 <p>passive immunity</p>	 <p>thymus</p>	 <p>antibody</p>	 <p>skin</p>

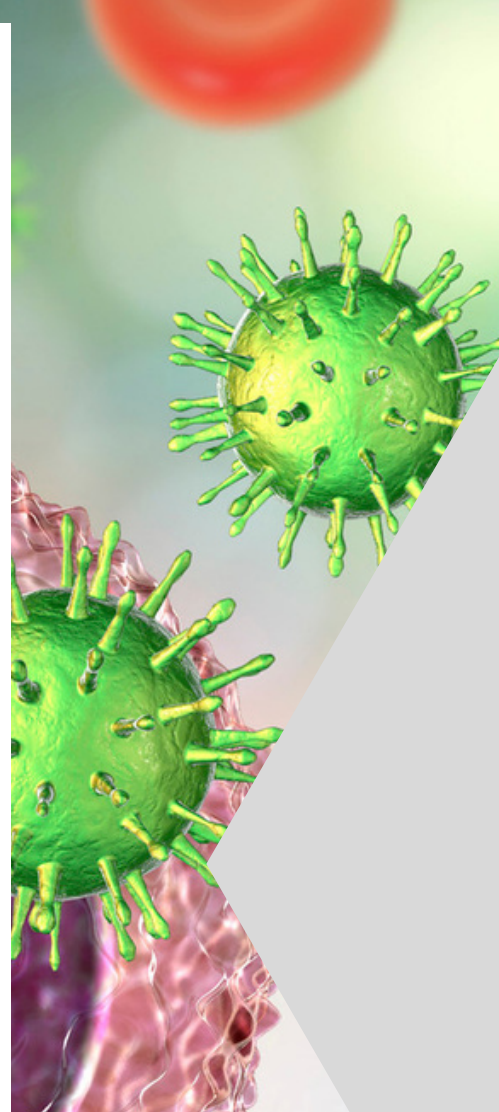

There is a matching activity included. Here, students will match characteristics about the immune system (These are reviewed in the book.)

Use the pictures on the next page to finish the sequence of how your immune system works.

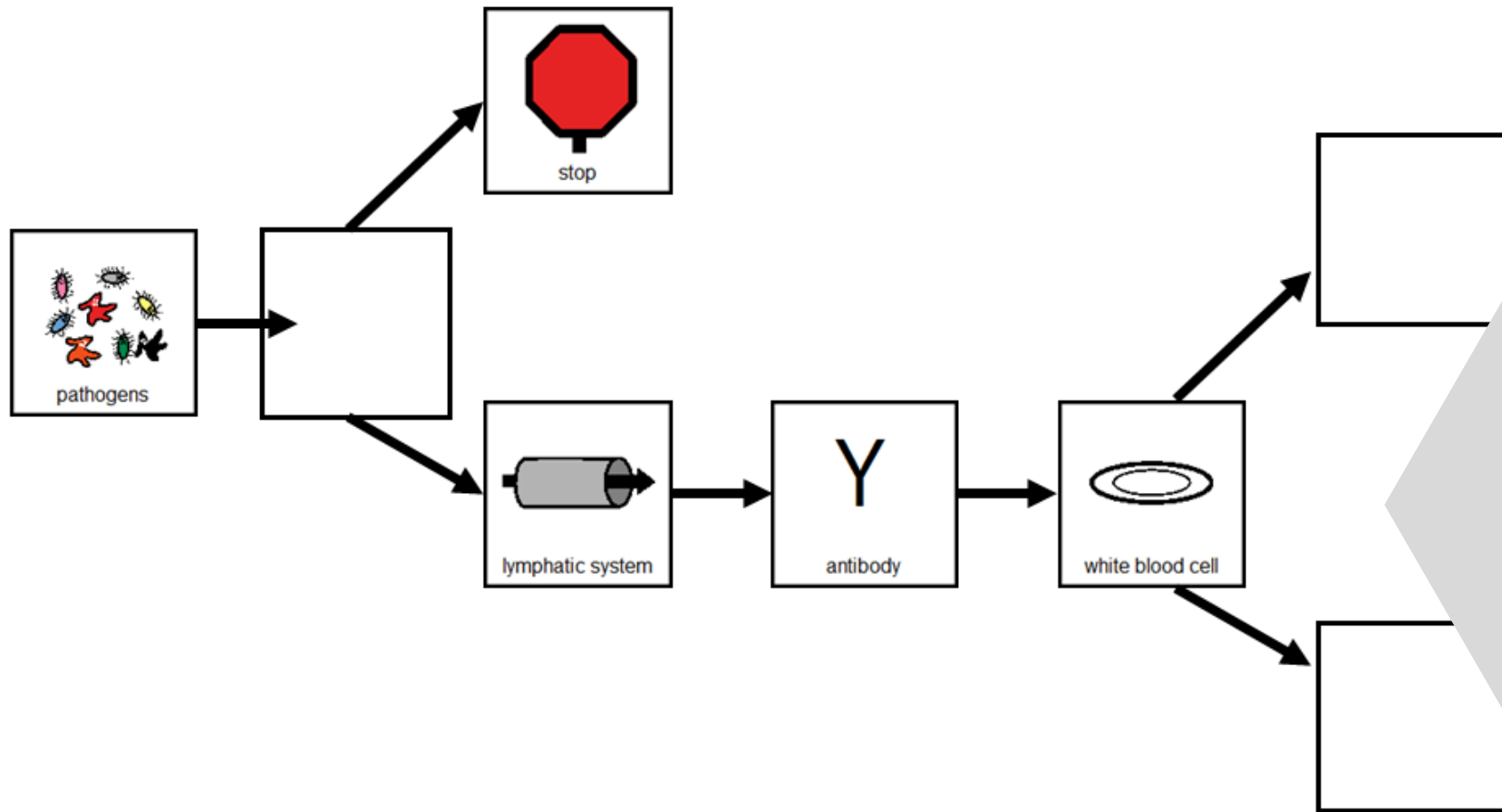





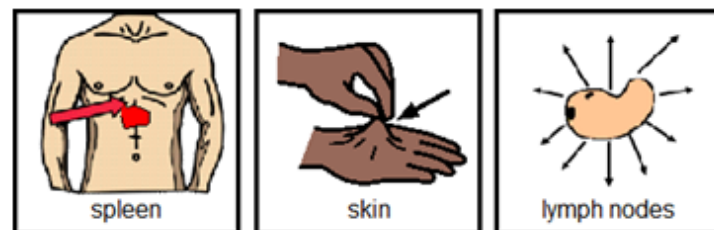



Christa Joy, Special Needs for Special Kids  
The Picture Communication Symbols ©1981–2020 by Tobii Dynavox. All Rights Reserved  
Worldwide. Used with permission. Boardmaker® is a trademark of Tobii Dynavox











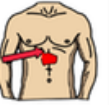
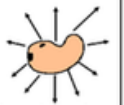

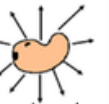
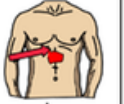

There are 3 sequencing activities included. Each one has more steps missing. Each one has a color coded version included. Students then add the X where a defect in the immune system would interfere with that process.



# Immune System

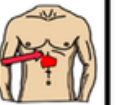



		 lymphocyte	
	Y antibodies	 pathogen	
	 pathogen	 vaccine	 lymphocyte
 vaccine	 lymphocyte		 pathogen

# Immune System

 spleen			 lymph nodes		 vaccine
 lymph nodes			 spleen		
 lymphocyte			 vaccine	 lymph nodes	
 vaccine	 spleen		 lymphocyte		
 pathogen		 spleen	Y antibodies		
Y antibodies	 lymphocyte	 vaccine	 pathogen		

There is a Sudoku puzzle in this unit as well. This is a great way to work with the new vocabulary!!

There are 2 versions plus answer keys.

 pathogens	 lymphocyte	 vaccine	 vaccine
Y antibodies	Y antibodies	Y antibodies	

# Immune System

ZZ IMMUNITY STAFSTLYMO  
 YMLMRAVDZQIMNOMNEAYC  
 SJFJDMKXCXMAVXFUQTFC  
 RHFRIZTJHIMOPATHOGEN  
 RCBOLBCOZTUPPWEJYZXF  
 DTHXYBBDKDNIECAYLLIK  
 NRGVMVAKHKORWTDZLLRR  
 CTGDPGPIRCDHEZXFPLDX  
 XQYSHNKHZBEIACTIVEPH  
 ROCPNCSADLFRWKEHUHWA  
 SNNLOULNLMIQBOVZAFMU  
 ZDZEDYNSFWCVFCAPXWNT  
 GVREEDKKBXILUUCANTCO  
 IMWNSTFCBQENUKSCSMI  
 ZXMRWOGFVCNMABISDHTM  
 SWDQLYMPHOCYTENIRCHM  
 FGUNCWESYHYCEUEVPYYU  
 QFZOBXRZJIYADQVIETFMN  
 GKANTIBODIESJOCTUOUE  
 SMWVYDERNSDIABETESSF

- |                  |            |            |             |
|------------------|------------|------------|-------------|
| immunodeficiency | lymphocyte | antibodies | lymph nodes |
| autoimmune       | pathogen   | immunity   | diabetes    |
| spleen           | vaccine    | active     | passive     |
| thymus           |            |            |             |

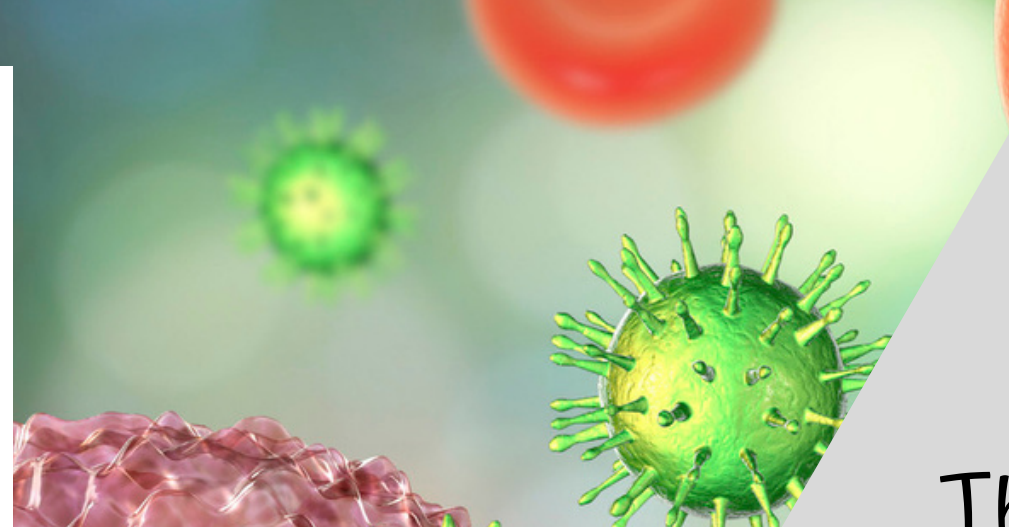

# Immune System

ZZ IMMUNITY STAFSTLYMO  
 YMLMRAVDZQIMNOMNEAYC  
 SJFJDMKXCXMAVXFUQTFC  
 RHFRIZTJHIMOPATHOGEN  
 RCBOLBCOZTUPPWEJYZXF  
 DTHXYBBDKDNIECAYLLIK  
 NRGVMVAKHKORWTDZLLRR  
 CTGDPGPIRCDHEZXFPLDX  
 XQYSHNKHZBEIACTIVEPH  
 ROCPNCSADLFRWKEHUHWA  
 SNNLOULNLMIQBOVZAFMU  
 ZDZEDYNSFWCVFCAPXWNT  
 GVREEDKKBXILUUCANTCO  
 IMWNSTFCBQENUKSCSMI  
 ZXMRWOGFVCNMABISDHTM  
 SWDQLYMPHOCYTENIRCHM  
 FGUNCWESYHYCEUEVPYYU  
 QFZOBXRZJIYADQVIETFMN  
 GKANTIBODIESJOCTUOUE  
 SMWVYDERNSDIABETESSF

- |                  |            |            |             |
|------------------|------------|------------|-------------|
| immunodeficiency | lymphocyte | antibodies | lymph nodes |
| autoimmune       | pathogen   | immunity   | diabetes    |
| spleen           | vaccine    | active     | passive     |
| thymus           |            |            |             |

There is also a word search to work with vocabulary. If your students cannot do a word search, have them highlight the circle words on the answer key.



## The Immune System

1. The immune system fights millions of  every day.

2. The  is the first line of defense.

3. If the pathogen gets into the body, it usually travels to the .

4. The lymphatic system moves pathogens and extra  into the blood.

5. Large Y-shaped proteins called  attach to the pathogen.

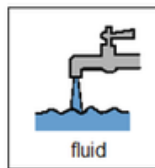

Y

antibodies

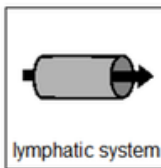
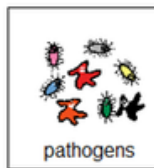

## Disorders of the Immune System

1. An immunodeficiency means your immune system is .

2. When your immune system is weak, you are  often and for longer.

3. If you have an autoimmune disease, the immune system attacks  cells and tissues.

4. Type 1 diabetes is an example of an  disease.

5. Problems with your immune system are  common.

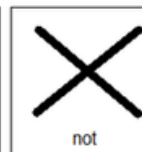
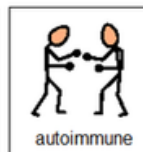

Close worksheet are a great informal assessment. This unit has 2 as an overview and one on disorders of the immune system.

Answer key included.

1. What does the immune system protect you from?



2. Where does your passive immunity come from?



3. What can you get at the doctor that helps you build your active immunity?

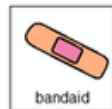

4. This system takes the extra fluid back

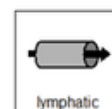
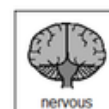

5. These are special proteins that attach to pathogens.

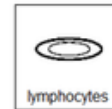

1. What does the immune system protect you from?
  - A. Smoke
  - B. Pathogens
  - C. trash
2. Where does your passive immunity come from?
  - A. Doctor
  - B. Dad
  - C. Mom
3. What can you get at the doctor that helps you build your active immunity?
  - A. Vaccine
  - B. Lollipop
  - C. bandaid
4. This system takes the extra fluid back to the blood stream.
  - A. Nervous
  - B. Lymphatic
  - C. skeletal
5. These are special proteins that attach to and attack the pathogens.
  - A. Fruit
  - B. Lymphocytes
  - C. antibodies
6. What are the main cells that fight disease in the body?
  - A. Brain cells
  - B. Tongue
  - C. lymphocytes

Print onto cardstock or mount on index cards. Cut pictures apart and show student answer choices for each question.

Q 3

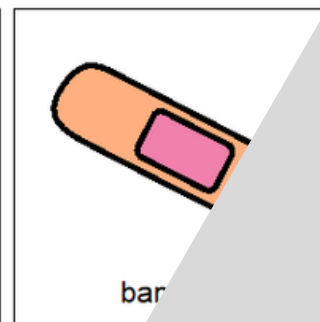
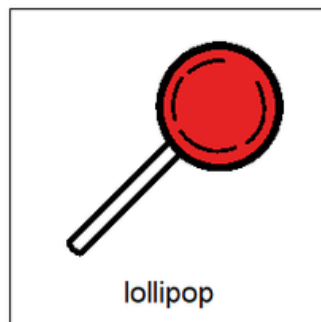
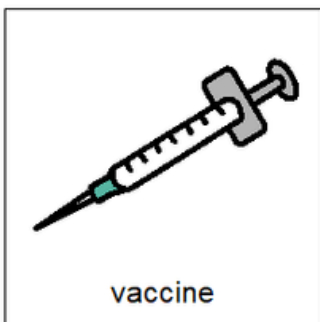

Q 4

Version 3

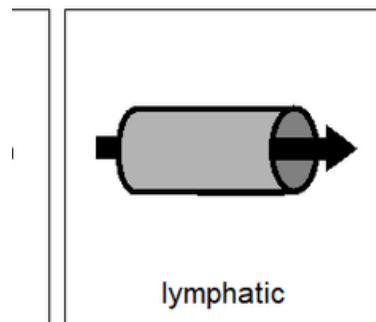

FINALLY the assessment!!  
There are 3 versions. This version has 10 questions with 3 picture choices for each question.

Answer key included.

- *This unit includes digital versions of the activities. These simply require the student to click and drag the answers. There is no drawing or typing involved.*
- *There are 2 complete sets of slides. One set is differentiated using color.*

**Make great independent learning centers.**



Watch the movie  
on the Immune  
System

Even though they are dead, these pathogens are  
enough to get your body to make antibodies.  
In other words, if you ever come in contact with the  
disease, your body will already have its secret  
weapon ready to go.



Christa Joy, Special Needs for Special Kids

*This unit also includes digital  
versions of the activities.  
Students can watch a movie  
book version of the book rather  
than printing it out.*

**Use for more review.**

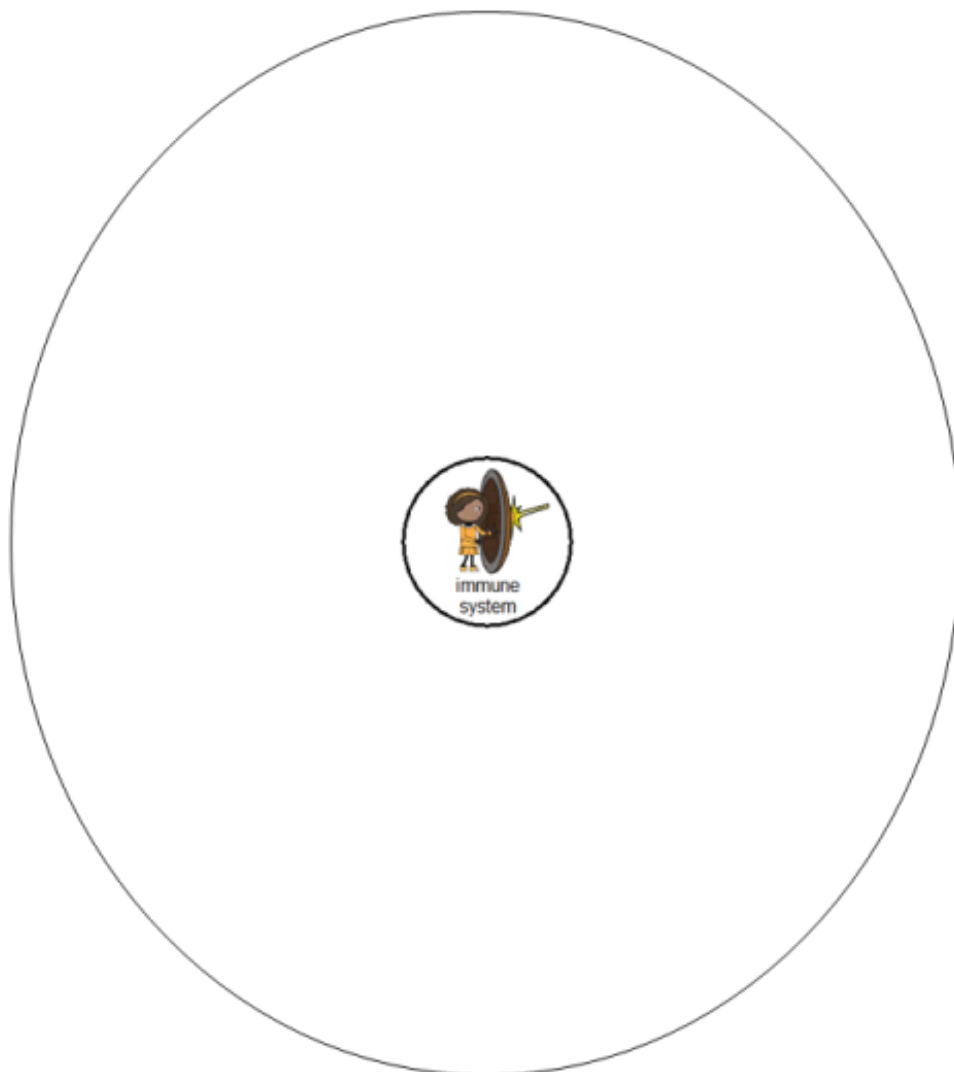

Place the pictures in the circle map about the immune system.

 pathogens	 lymphatic system	 spleen	
 active immunity	 passive immunity	 vac	
 lymph node	 thymus		

Each activity is set up so students can click and drag answers. No typing is required.

**Perfect for any learning level.**

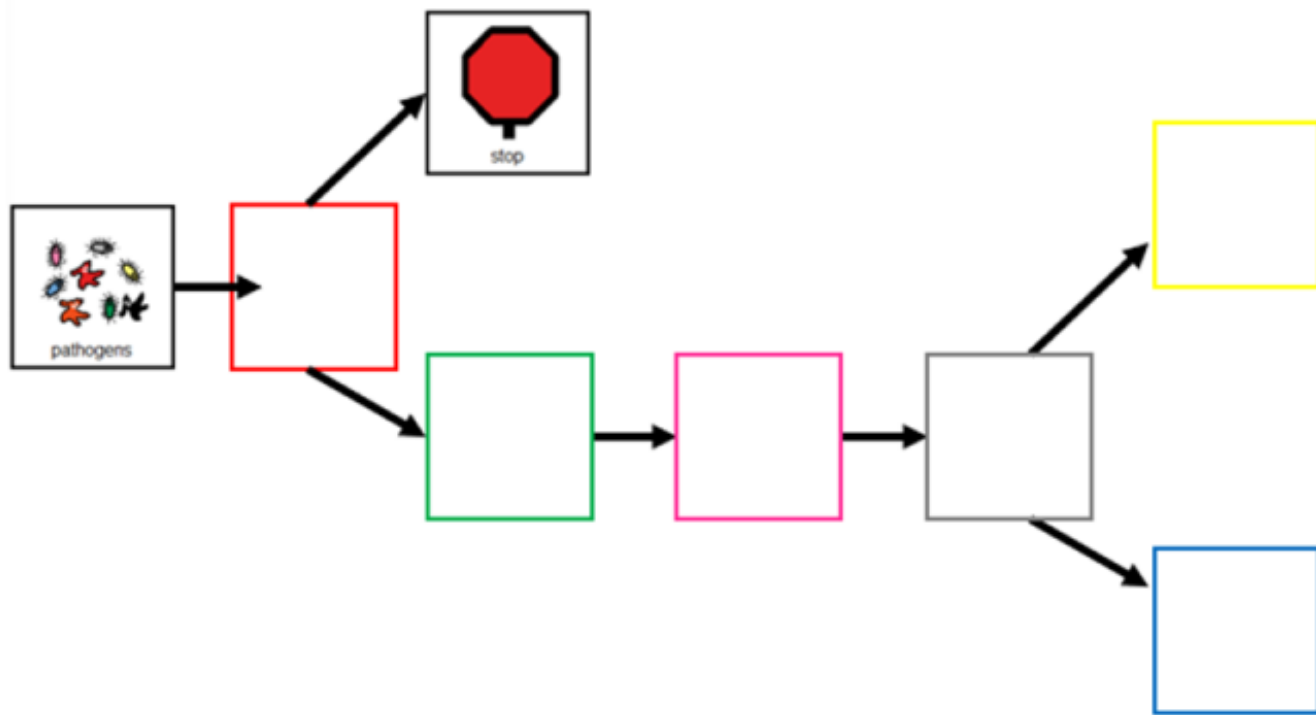

Finish the sequence showing how your immune system works

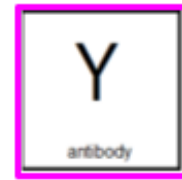
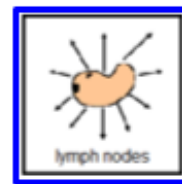
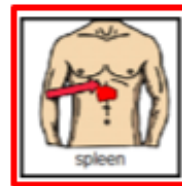

The second set of slides uses color for differentiation and extra support for students who may need it. Mix and match slides from both sets to make the perfect set for each student.

**Save money and get this as part of the Human Anatomy Bundle: Advanced Systems.**

**Also includes:**

- **Integumentary System**
- **Urinary/Reproductive System**
- **Circulatory System**
- **Endocrine System**
- **5 Senses**

**[CLICK HERE](#)**

